

Metering gear pumps

1611-4-1 / 1611-4-2

Application fields

This pump is mainly fitted for water or solvant based automotive and industrial paint.

Strong points

- All parts are in tempered stainless steel
- Reduction of “dead zones” allowing for a better flushing
- New sealing technology combining lip seals and liquid barrier
- Sealing options quickly interchangeable
- Strong, coated drive shaft, held in place with 2 bearings and a axial thrust
- Centering pins making pump assembly easier and increasing its accuracy
- Possibility to mount a bypass system (for type 1611-4-2)

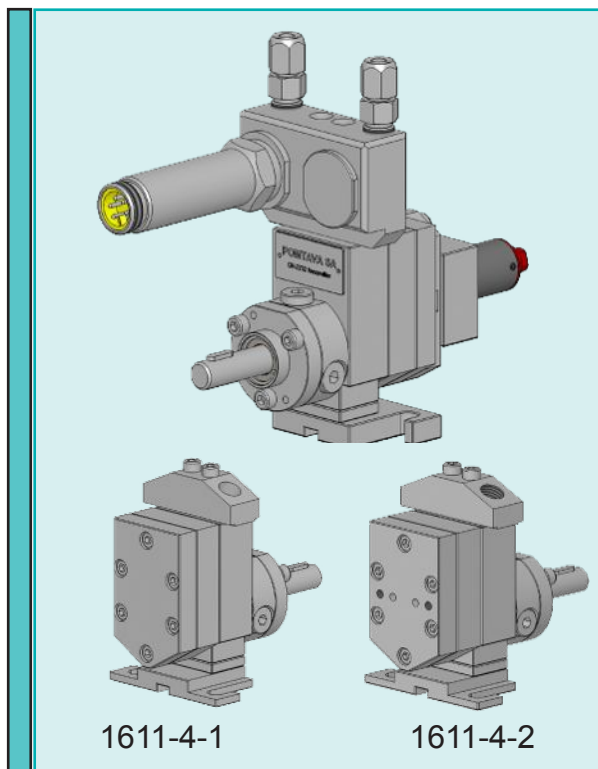

Technical data

Sealing :	Lip seals and liquid barrier
Rotation speed :	From 10min ⁻¹ to 200min ⁻¹ , depending on the product involved
Standard rotation :	Clockwise rotation (A)
Output pressure :	Max. 15 bars
Input/Output :	2 holes Ø 6mm on the body of the pump. Delivered with connecting block G1/4”
Driving shaft diameter :	Ø12mm with a 4mm key
Drive shaft height :	H=40mm

Available outputs

0.3cc/rev	0.6 cc/rev	1.2cc/rev	1.8cc/rev	2.4cc/rev	3.0cc/rev
-----------	------------	-----------	-----------	-----------	-----------

Available options

- **(T2)** Entirely treated with ADLC
- **(H51)** Stand H=51mm compatible with Group 1 and 2
- **(Z)** Counterclockwise rotation
- **(AZ)** Clockwise and counterclockwise rotation
- **(BB)** Bypass block (for type 1611-4-2)
- **(W)** Connecting block for 2 pressure sensors M28x1.5
- **(AB38)** Connecting block G3/8”

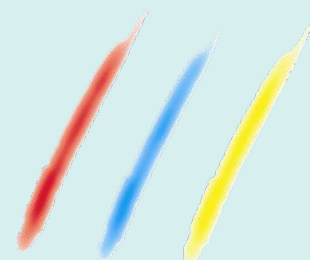

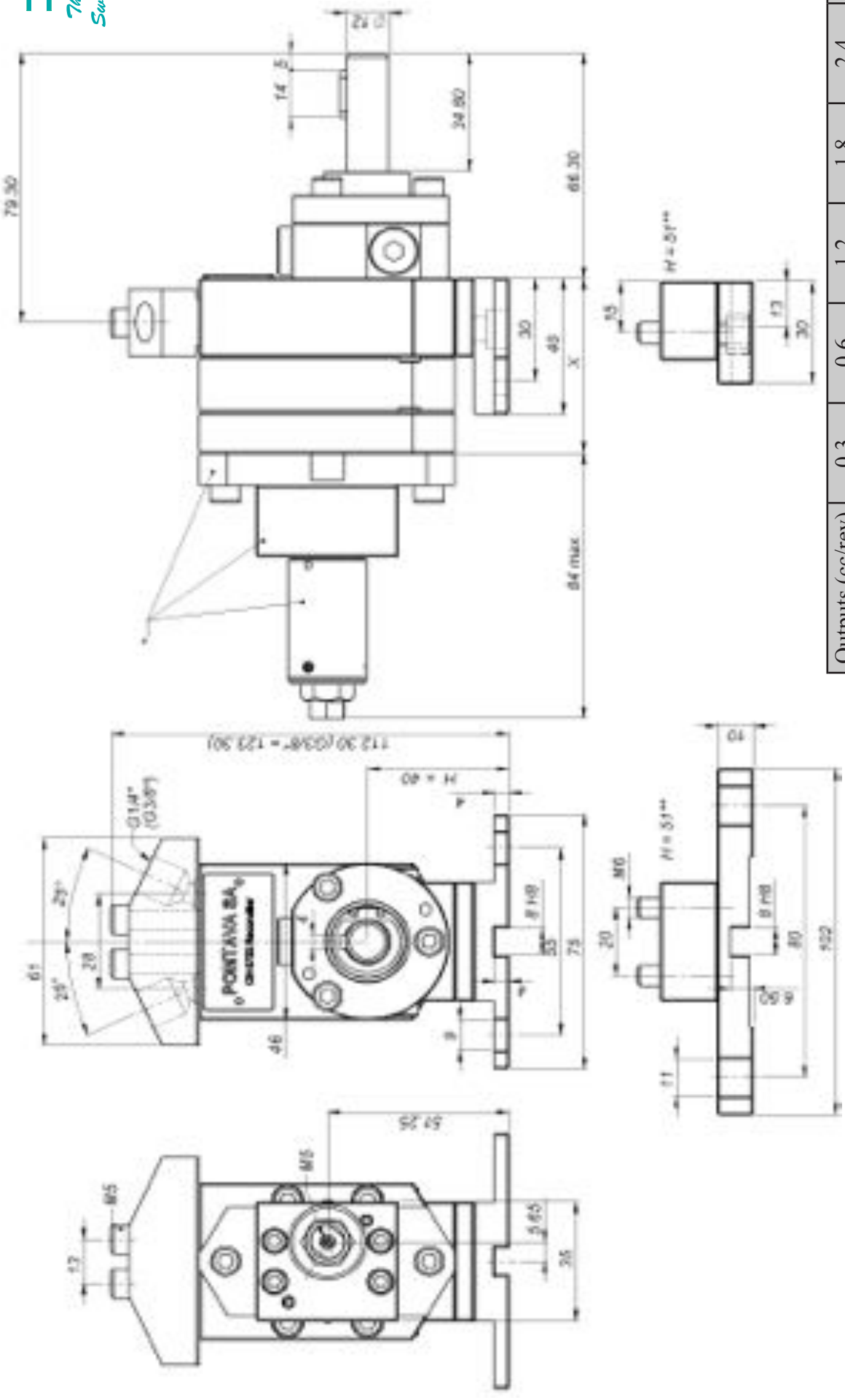

Outputs (cc/rev)	0.3	0.6	1.2	1.8	2.4	3.0
X (mm)	36	38.5	44	43	46	49.5

* Option block bypass (for type 1611-4-2) ** Option H51